

PRODUCT SPECIFICATION

MODEL: HK-101R28H01

< ◇ > PRELIMINARY SPECIFICATION

< ◆ > APPROVAL SPECIFICATION

CUSTOMER
APPROVED BY
DATE:

DESIGNED	CHECKED	APPROVED

REVISION STATUS

Version	Revise Date	Page	Content	Modified by
V1.0	2018.11.30	-	First Issued.	Jason

www.hkbykj.cc

CONTENTS

1. GENERAL DESCRIPTION	P.4
2. MECHANICAL SPECIFICATION	P.5
3. PIN DESCRIPTION.....	P.6
4. BLOCK DIAGRAM.....	P.7
5. ELECTRICAL CHARACTERISTICS	P.8
6. INPUT SIGNAL CHARACTERISTICS	P.13
7. OPTICAL CHARACTERISTICS	P.15
8. QUALITY ASSURANCE SYSTEM	P.19
9. GENERAL PRECAUTION	P.20
10. PACKAGE DRAWING.....	P.21

www.hkbykj.com

1. GENERAL DESCRIPTION

1.1 DESCRIPTION

AINFULL Display model HK-101R28H01 is a transmissive type color active matrix liquid crystal display (LCD) which uses amorphous thin film transistor (TFT) as switching devices. This product is composed of a TFT LCD panel, driver ICs and a backlight unit. The following table describes the features of this LCM.

1.2 FEATURES

No.	Item	Specification	Unit
1	Panel Size	10.1	inch
2	Number of Pixels	800 × 3(RGB) ×1280	pixels
3	Active Area	135.36(H) ×216.58(V)	mm
4	Pixel Pitch	0.1692(H) ×0.1692(V)	mm
5	Outline Dimension	143.1(H) × 228.55(V) × 2.50(D)	mm
6	Pixel arrangement	RGB Vertical stripe	-
7	Display Mode	IPS with Normally Black	-
8	Viewing Direction	ALL Viewing Direction	-
9	Display Color	16.7M	-
10	Surface Treatment	Anti-Glare and Hard-coating 3H	-
11	Interface	LVDS	-
12	Backlight	White LED	-
13	Drive IC	-	-
14	Operation Temperature	0~50	°C
15	Storage Temperature	-20~60	°C
16	Weight	240(Typ.)	g

2. MECHANICAL SPECIFICATION

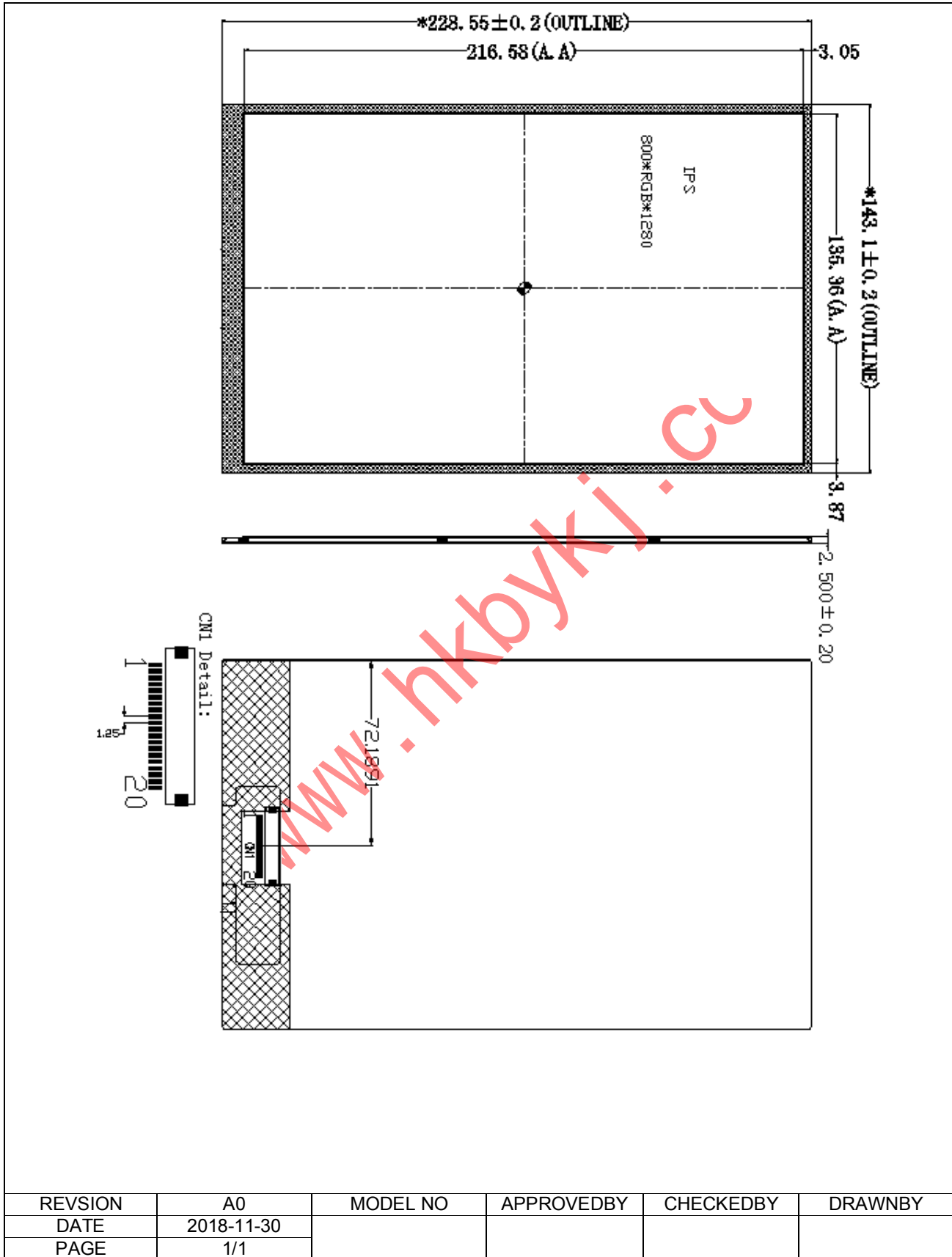

3. PIN DESCRIPTION

3.1 CN1 of FPC

Pin No.	Symbol	I/O	Function	Remark
1	VDDIN	P	Power supply VDDIN=3.3V	
2	VDDIN	P	Power supply VDDIN=3.3V	
3	LED_EN	I	Backlight Enable Signal,3.3V~5V.	
4	GND	P	Ground	
5	RXIN0N	I	-LVDS differential data	
6	RXIN0P	I	+LVDS differential data	
7	GND	P	Ground	
8	RXIN1N	I	-LVDS differential data	
9	RXIN1P	I	+LVDS differential data	
10	GND	P	Ground	
11	RXIN2-	I	-LVDS differential data	
12	RXIN2+	I	+LVDS differential data	
13	GND	P	Ground	
14	RX_CLKN	I	-LVDS differential clock input	
15	RX_CLKP	I	+LVDS differential clock input	
16	GND	P	Ground	
17	RXIN3-	I	-LVDS differential data	
18	RXIN3+	I	+LVDS differential data	
19	PWM	I	Backlight brightness:apply 0.7V to 1.4V DC voltage signal	
20	VLED	P	Power supply VLED=5~12V(Typ.)	

Note: I/O definition:

I: input, O: output, P: Power,

-: No Connection

4. BLOCK DIAGRAM

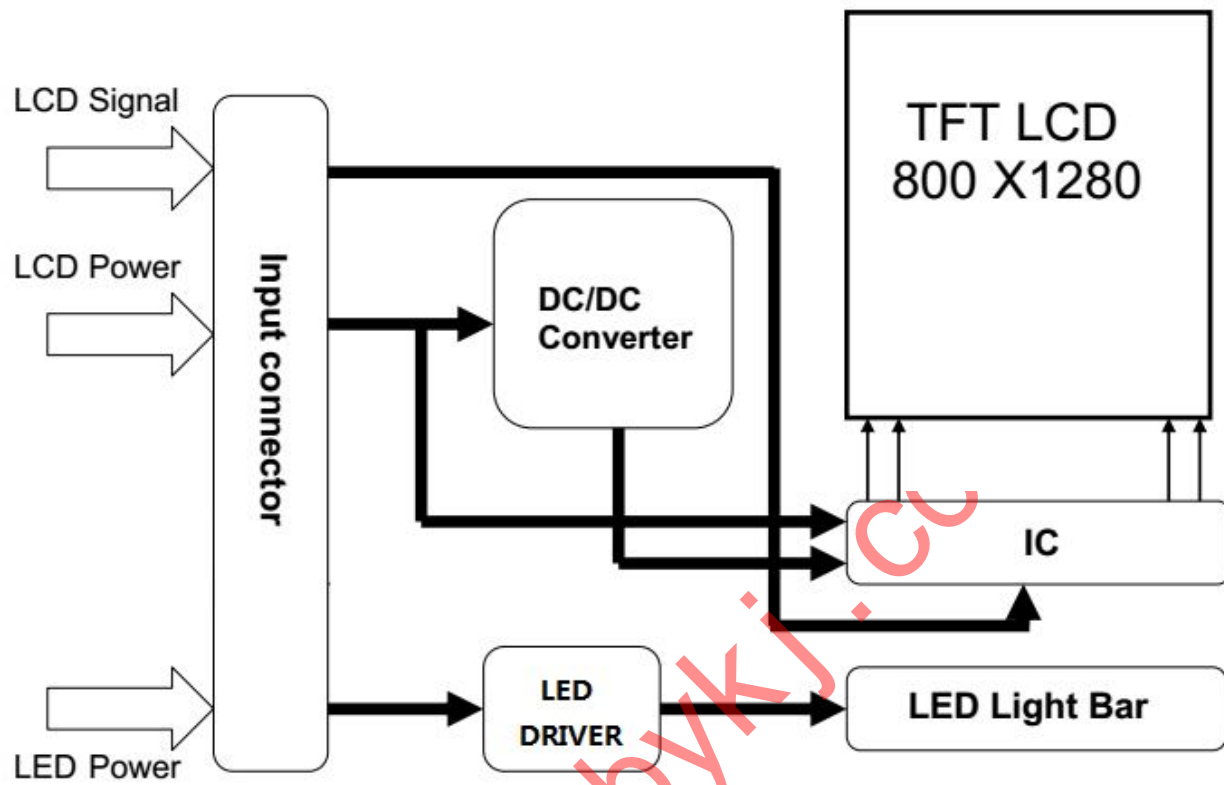

5. ELECTRICAL CHARACTERISTICS

5.1 ABSOLUTE MAXIMUM RATINGS

AGND=GND=0V, Ta = 25 °C

Item	Symbol	Values		Unit	Remark
		Min.	Max.		
Power voltage	VDD-VSS	-0.5	5.0	V	
	VDD3-VSS	-0.5	13.5	V	
	VCI-VSS	-0.3	42	V	

5.2 RECOMMENDED OPERATING CONDITION

AGND=GND=0V, Ta = 25°C

Item	Symbol	Values			Unit	Remark
		Min.	Typ.	Max.		
Digital Supply Voltage	VDD	3.0	3.3	3.6	V	-
Power IC provides voltage	AVEE	-6	-5	-4.5	V	-
	AVDD	4.5	5.5	6.0	V	-
Driver IC provides voltage internally	VGH	9	-	20	V	-
	VGL	-20	-	-9	V	-
Input Signal Voltage	Low Level VIL	0	-	0.3*VDD	V	-
	High Level VIH	0.7*VDD	-	VDD	V	

5.3 POWER GENERATION

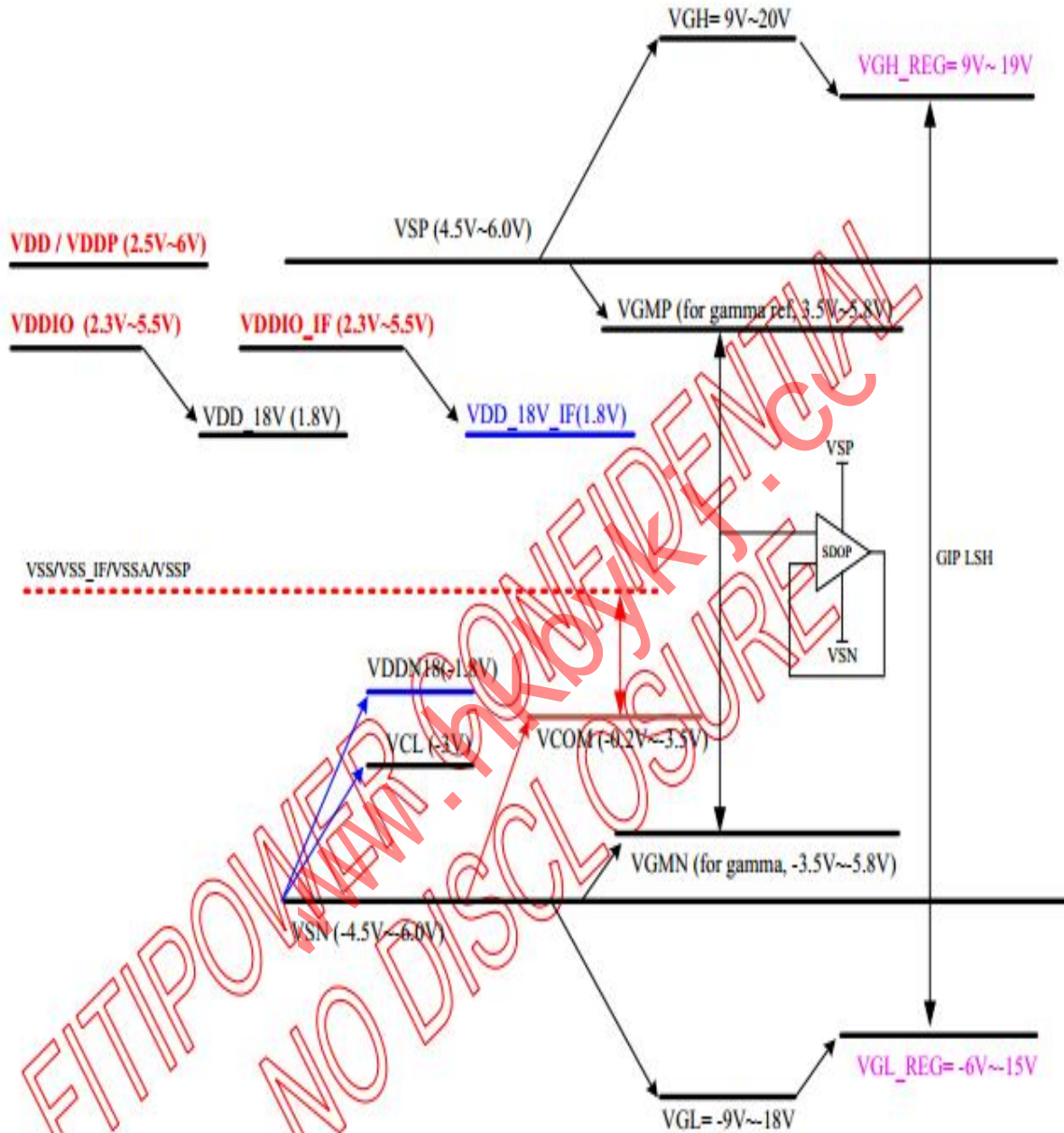

5.4 POWER SEQUENCE

5.4.1 Power on sequence PMODE[1:0]=00b

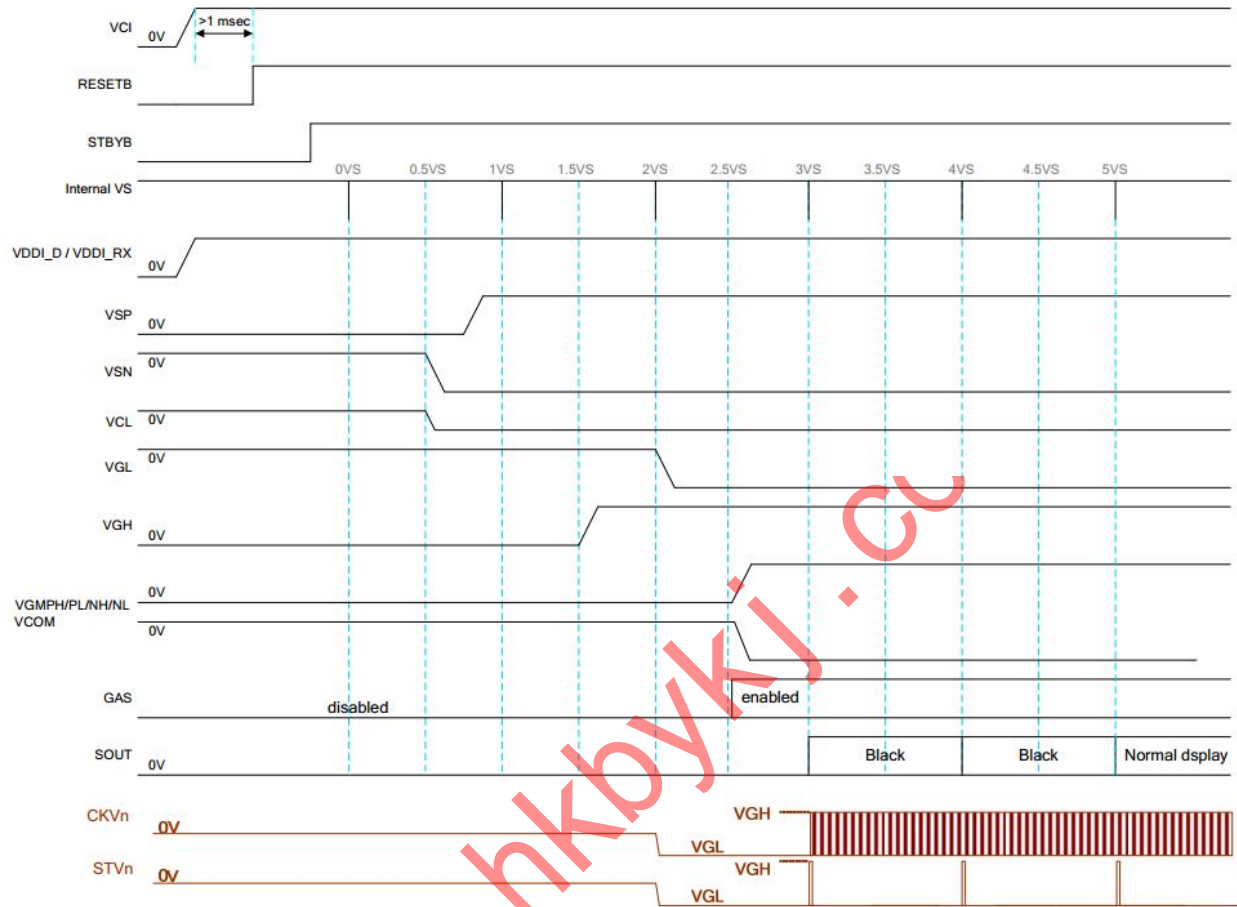

5.4.2 Power off sequence PMODE[1:0]=00b

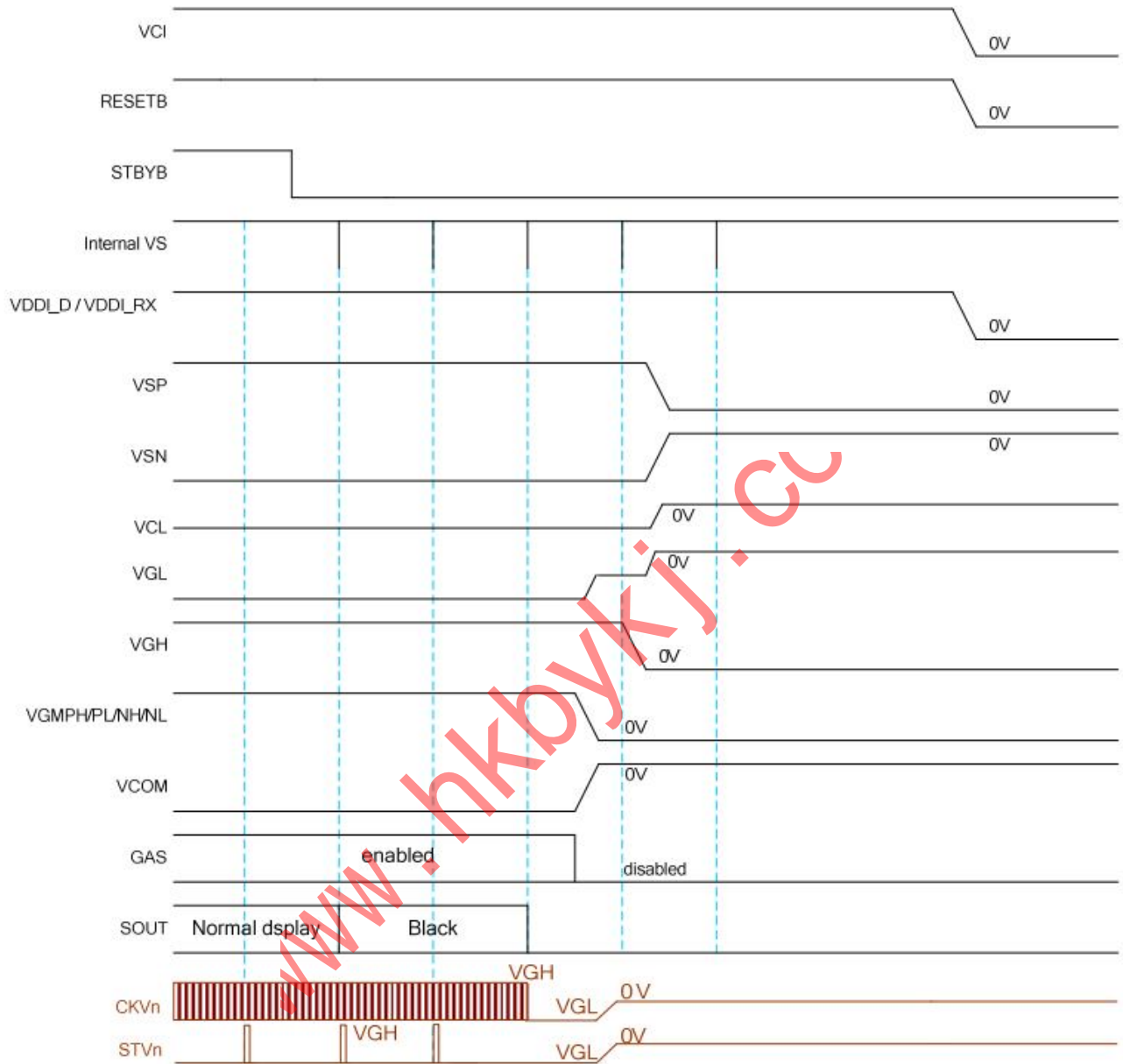

5.5 BACKLIGHT UNIT

Item	Symbol	Values			Unit	Remark
		Min.	Typ.	Max.		
Forward voltage	VF	19.5	21	22.5	V	IF=20mA/1-chip
Forward current	IF	-	80	-	mA	
PWM Signal Voltage	PWM_h	2.0	3.3	3.6	V	-
PWM Signal Voltage	PWM_l	0	-	0.5	V	-
Output PWM frequency	PWM_f	-	200	1000	Hz	-
LED enable Voltage	EN_h	2.6	3.3	3.6	V	-
	EN_l	0	-	0.4	V	-

5.5.1 Internal Circuit Diagram



6. INPUT SIGNAL CHARACTERISTICS

6.1. LVDS/MIPI INPUT TIMING TABLE

Item	Symbol	Values			Unit	Remark
		Min.	Typ.	Max.		
DCLK frequency	F _{DCLK}	-	60	-	MHz	-
HSYNC period time	T _H	-	920	-	DCLK	-
Horizontal display area	T _{HD}	-	800	-	DCLK	-
HSYNC pulse width	T _{HPW}	-	24	-	DCLK	-
HSYNC back porch	T _{HBP}	-	24	-	DCLK	-
HSYNC front porch	T _{FBP}	-	72	-	DCLK	Data to DCLK
VSYNC period time	T _V	-	1304	-	ns	Data to DCLK
Vertical display area	T _{VD}	-	1280	-	ns	-
VSYNC pulse width	T _{VPW}	-	2	-	ns	-
VSYNC back porch	T _{VBP}	-	10	-		
VSYNC front porch	T _{VFP}	-	12	-		

Frequency=(Frame rate) x T_H x T_V x 24bits

6.2. LVDS INTERFACE

6.2.1. Data input format for LVDS

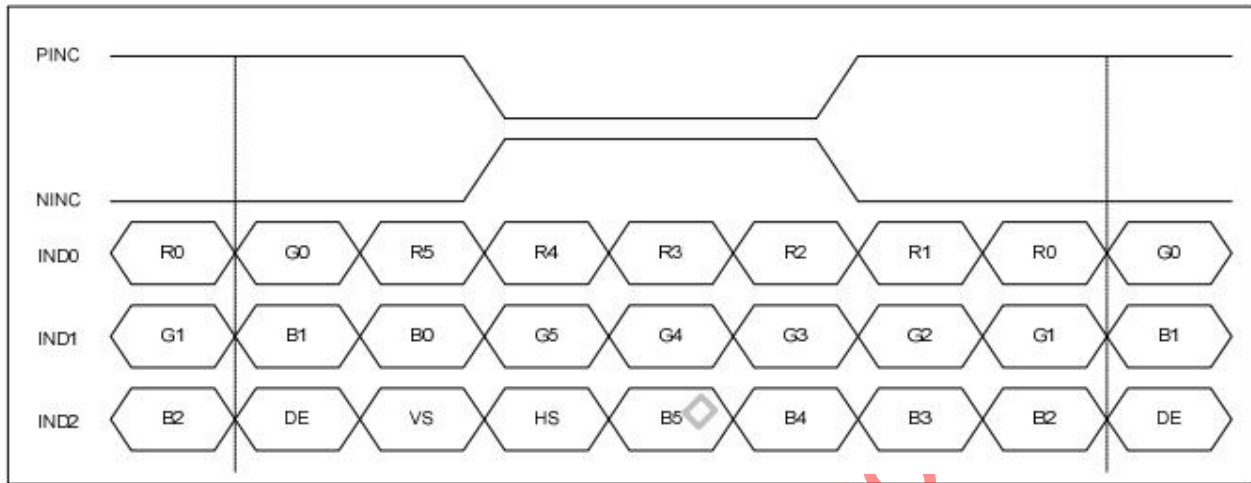

6-bit LVDS input



8-bit LVDS Input

6.2.2.LVDS mode AC electrical characteristics

Parameter	Symbol	Spec.			Unit	Condition
		Min.	Typ.	Max.		
Clock frequency	R_{XFCLK}	20	-	85	MHz	-
Input data skew margin	T_{RSKM}	500	-	-	pS	$ V_{ID} =400mV$ $R_{XVCM}=1.2V$ $R_{XFCLK}=71MHz$
Clock high time	T_{LVCH}	-	$4/(7 \cdot R_{XFCLK})$	-	ns	-
Clock low time	T_{LVCL}	-	$3/(7 \cdot R_{XFCLK})$	-	ns	-
PLL wake-up time	T_{enPLL}	-	-	150	μs	-

Table 13.1: LVDS mode AC electrical characteristics

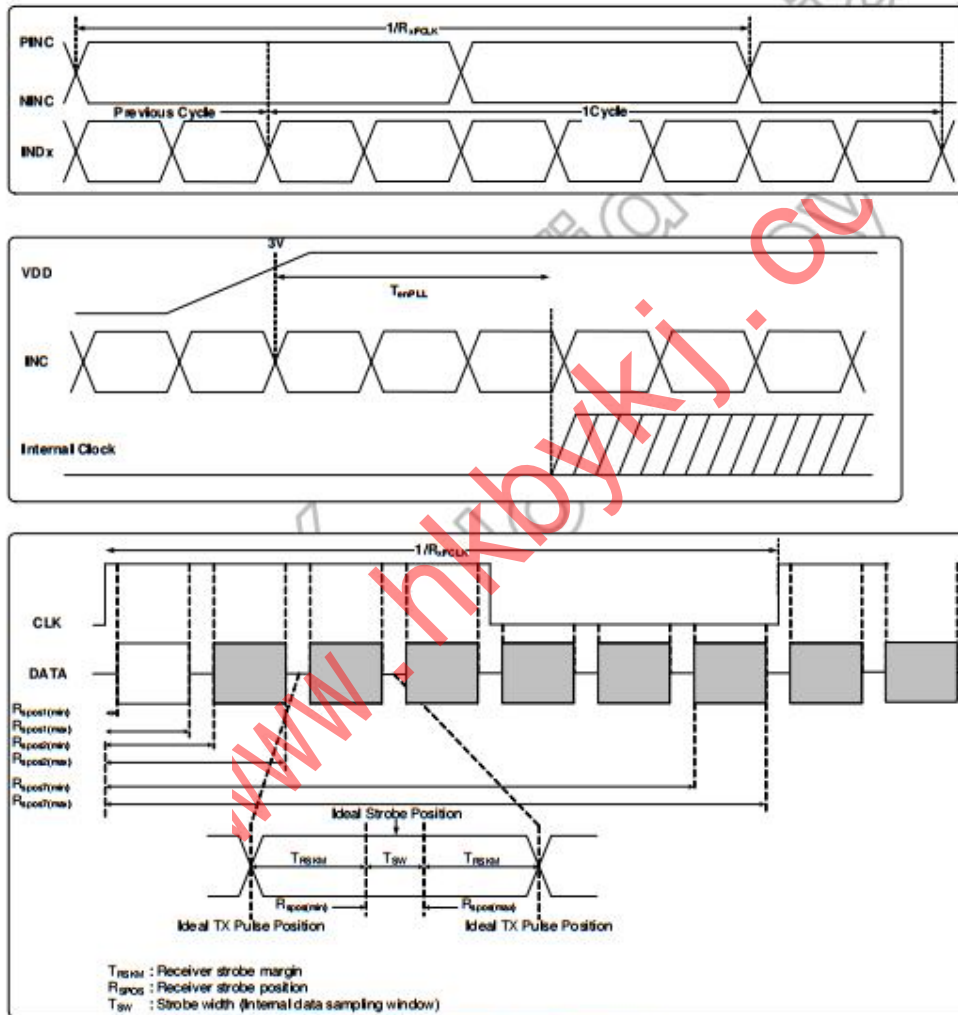

Figure 13.3: LVDS figure

Parameter	Symbol	Spec.			Unit	Condition
		Min.	Typ.	Max.		
Modulation frequency	SSC_{MF}	23	-	93	KHz	-
Modulation rate	SSC_{MR}	-	-	± 3	%	LVDS clock =71 MHz center spread

Table 13.2: SSC table

7. OPTICAL CHARACTERISTICS

Light source :c-light(with normal polarizer)

Item	Symbol	Condition	Values			Unit	Remark	
			Min.	Typ.	Max.			
Viewing angle	Θ_U	$CR \geq 10$	80	85	-	degree	Note2	
	Θ_D		80	85	-			
	Θ_L		80	85	-			
	Θ_R		80	85	-			
Response time	$T_{ON}+T_{OFF}$	$\theta=\phi=0^\circ$ Normal viewing angle	-	30	35	ms	Note1 Note3	
Contrast ratio	CR		600	800	-	-	Note1 Note4	
Luminance	L		230	250	-	cd/m ²		
Luminance uniformity	YU		75	-	-	%		
Color chromaticity (CIE1931)	White		WX	0.276	0.296	0.316		Note1 Note5
			WY	0.302	0.322	0.342		
	Red		RX	0.601	0.621	0.641		
			RY	0.294	0.314	0.334		
	Green		GX	0.252	0.272	0.292		
			GY	0.560	0.580	0.600		
	Blue	BX	0.121	0.141	0.161			
		BY	0.093	0.113	0.133			
NTSC			60%					

Test Conditions:

- 1.Measuring surrounding:dark room
- 2.The ambient temperature is $25\pm 2^\circ\text{C}$.
- 3.The test systems refer to Note1 and Note2.

Note1: Definition of optical measurement system

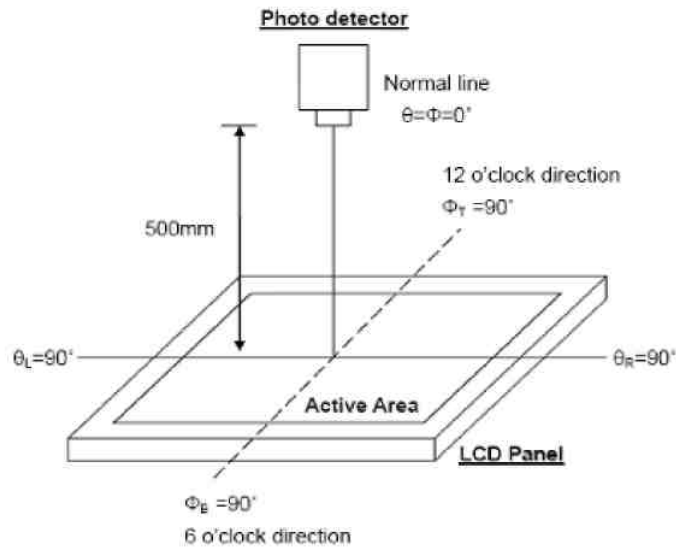

Note2: Definition of viewing angle range and measurement system

Viewing angle is measured at the center point of the LCD by CONOSCOPE (ergo-80).

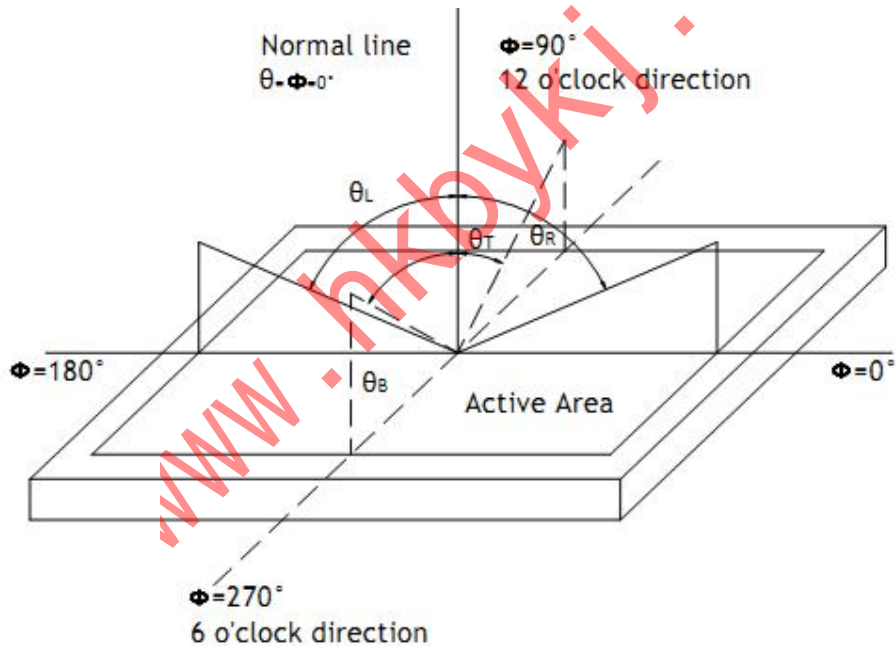

Note3: Definition of Response time

The response time is defined as the LCD optical switching time interval between "White" state and "Black" state. Rise time (TON) is the time between photo detector output intensity changed from 90% to 10%. And fall time (TOFF) is the time between photo detector output intensity changed from 10% to 90%.

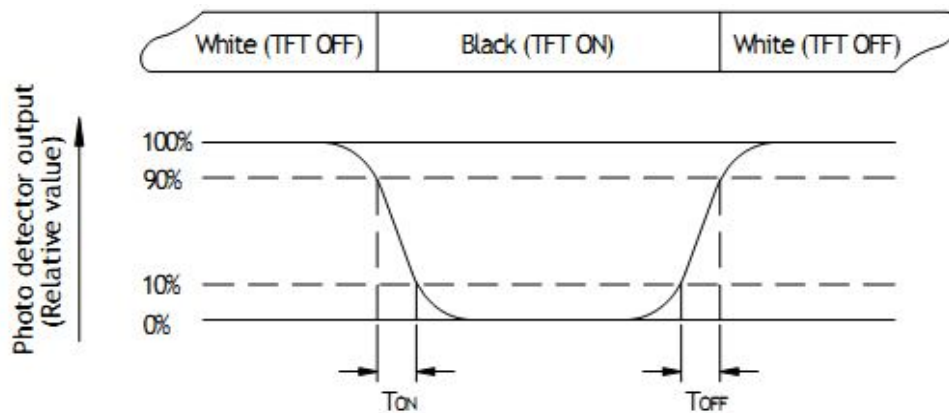

Fig. 6-3 Definition of response time

Note4: Definition of contrast ratio

$$\text{Contrast ratio (CR)} = \frac{\text{Luminance measured when LCD on the Whitestate}}{\text{Luminance measured when LCD on the Blackstate}}$$

“White state “: The state is that the LCD should drive by V_{white} .

“Black state”: The state is that the LCD should drive by V_{black} . ♦

V_{white} : To be determined V_{black} : To be determined.

Note5: Definition of color chromaticity (CIE1931)

Color coordinates measured at center point of LCD.

Note6: All input terminals LCD panel must be ground while measuring the center area of the panel.

The LED driving condition is $I_L=20\text{mA}$ of which each LED module is 3 LED serial.

Note7: Definition of Luminance Uniformity

Active area is divided into 9 measuring areas. Every measuring point is placed at the center of each measuring area.

$$\text{Luminance Uniformity (U)} = L_{min} / L_{max}$$

L--- Active area length, W--- Active area width

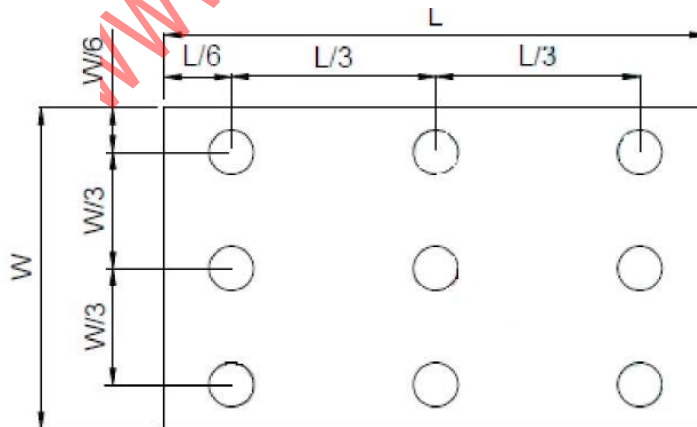

B_{max} : The measured maximum luminance of all measurement position.

B_{min} : The measured minimum luminance of all measurement position.

Note8: Definition of Luminance

Measure the luminance of white state at center point.

8. QUALITY ASSURANCE SYSTEM

8.1 TEMPERATURE AND HUMIDITY

Test Item	Test Condition
High Temperature Storage	Ta=60°C; 240hrs
Low Temperature Storage	Ta=-20°C; 240hrs
High Temperature Operation	Ta=50°C ; 240hrs
Low Temperature Operation	Ta=0°C; 240hrs
High Temperature High Humidity Operation	Ta=50°C ; 90%RH ; 240hrs(no condensation)
Thermal Shock	-20°C(0.5hrs) ~ 60°C(0.5hrs) / 100 cycles
Image Sticking	25°C ; 2hrs Note1

Note1:Condition of image sticking test :25°C±2°C

Operation with test pattern sustained for 4hrs,then change to gray pattern immediately.after5 mins,the mura must be disappeared completely

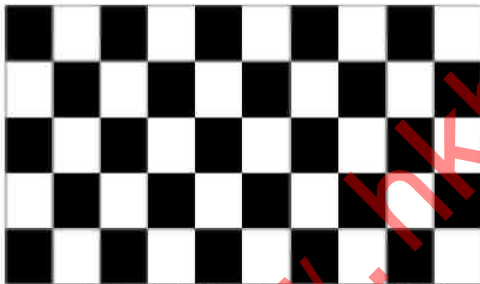

(a) Test Pattern (chess board Pattern)

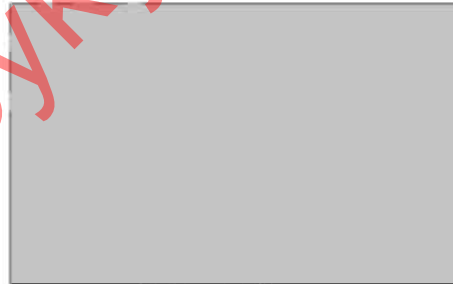

(b) Gray Pattern

8.2 VIBRATION & SHOCK

Test item	Conditions
Packing Shock (non-operation)	Shock level:980m/s ² Waveform:1/2 Sine wave,6msec ±X, ±Y ±Z,each axis 1 times
Packing Vibration (non-operation)	Frequency range:8 HZ~33.3HZ Stroke:1.0mm,sweep:10 HZ ~50 HZ x,y,z 2 hours for each direction

8.3 ESD

Test item	Conditions
Electro Static Discharge Test (non-operation)	150pF,330 Ω , Contact±4KV,Air : ±8KV Note 1
	200pF,0 Ω , ±200V Contact test.Note 2

Note1:LCD glass and metal bezel

Note2:IF connector pins

9. GENERAL PRECAUTION

9.1 SAFETY

- (1) Do not swallow any liquid crystal, even if there is no proof that liquid crystal is poisonous.
- (2) If the LCD panel breaks, be careful not to get liquid crystal to touch your skin.
- (3) If skin is exposed to liquid crystal, wash the area thoroughly with alcohol or soap.

9.2 STORAGE CONDITIONS

- (1) Store the panel or module in a dark place where the temperature is $23\pm 5^{\circ}\text{C}$ and the humidity is below $50\pm 20\% \text{RH}$.
- (2) Store in anti-static electricity container.
- (3) Store in clean environment, free from dust, active gas, and solvent.
- (4) Do not place the module near organics solvents or corrosive gases.
- (5) Do not crush, shake, or jolt the module.

9.3 HANDLING PRECAUTIONS

- (1) Avoid static electricity which can damage the CMOS LSI.
- (2) The polarizing plate of the display is very fragile. So, please handle it very carefully.
- (3) Do not give external shock.
- (4) Do not apply excessive force on the surface.
- (5) Do not wipe the polarizing plate with a dry cloth, as it may easily scratch the Surface of plate.
- (6) Do not use ketonics solvent & Aromatic solvent, use with a soft cloth soaked with a cleaning naphtha solvent.
- (7) Do not operate it above the absolute maximum rating.
- (8) Do not remove the panel or frame from the module.
- (9) When the module is assembled, it should be attached to the system firmly, Be careful not to twist and bend the module.
- (10) Wipe off water droplets or oil immediately. If you leave the droplets for a long time, staining and discoloration may occur.
- (11) If the liquid crystal material leaks from the panel, it should be kept away from the eyes or mouth. In case of contact with hands, legs or clothes, it must be washed away thoroughly with soap.

9.4 WARRANTY

- (1) The period is within twelve months since the date of shipping out under normal using and storage conditions.
- (2) Do not repaired or modified the LCM . It may cause function to lose efficacy , Starry does not warrant the LCM.
- (3) All process and material comply RoHS.

10. PACKAGE DRAWING

TBD

www.hkbykj.com